

TBArtists

www.tbartists.com

Middlebury, VT ~ New York, NY ~ Austin, TX

Hollis Brown

Contact Info. / Hospitality & Tech Rider / Stage Plot

IMPORTANT NOTE TO PROMOTERS

This rider is implicitly, if not explicitly, attached to the contract you were sent via email from an agent at TBArtists (TBA). If there is a discrepancy, the terms of the contract supercede the terms of the rider. For example, if the contract states "Buyer to provide limited beverage hospitality", the specifics of the hospitality requested in the rider may be disregarded. Please refer to the email and contract for questions pertaining to terms of the agreement. This rider represents the general needs or requirements of the artist, and the general conditions of the rider need to be understood even if certain specifics are not provided for in the contract.

Every bit of contact information and all available promotional resources for every artists represented by TBA is available at www.tbartists.com. The website is very easy to navigate. If you have questions about promotion or production (or anything unrelated to booking the artist) please direct them to the appropriate party by referring to www.tbartists.com.

Artist Hospitality Rider

This rider is attached to and made part of the agreement between **Hollis Brown** ("Artist") and _____ ("Venue" or "Buyer") for the performance on _____ 200__. Your cooperation in meeting the guidelines found within this agreement is appreciated to help insure the Venue, Artist and Audience the best possible experience. Should you have any problems in fulfilling this rider, please contact Tour Manager.

General Terms:

- ✍ **Stage** - The minimum size stage deck for the Artist's performance shall be at least 15' wide by 10' deep with one 8' wide x 6' deep x 6" high drum riser if available. The stage and drum riser shall be of sturdy construction; flat, level and free of tripping hazards. The stage deck and sub-structure shall not have sag or bounce that would cause amplifiers, speaker stacks or lighting rigs to lean or sway. Preferred stage elevation is to be a minimum of 24" above surrounding floor or grade. If the stage is not a permanent part of the venue, a loading ramp and an adequate set of stairs, both of safe and sturdy construction, should be provided. Outdoor stages should be properly covered to protect Artist and all equipment from the elements.
- ✍ **Security**- Buyer shall guarantee proper security at all times to ensure the safety and privacy of Artist, Artist crew and guests, all equipment, and personal property from the beginning of load-in until the completion of load-out. Buyer will be held financially responsible for any loss due to lack of proper security.
- ✍ **Taping and Cameras ARE allowed.** Video and Broadcasting of any sort, in any medium may be allowed only with Artist's prior consent. Please advance this issue with Tour Manager. All film, tapes and content of any Video or Broadcast will be the property of Artist unless a waiver, release or mechanical license agreement is signed by Artist or Management in advance.
- ✍ **Artist retains the non-negotiable right to record (audio or video) their performance or have it recorded for them, free of charge or limitation. Artist shall use their own recording gear if allowing a patch into the board poses a production issue for Buyer. This recording is the exclusive property of Artist, and Buyer shall not restrict or inhibit this activity in any way unless a request to do so is made when the contract and rider link are received by buyer.**
- ✍ **Billing**- Artists' name must appear with the appropriate billing in all printed advertising and must be mentioned in all radio spots. Billing is as follows: **Hollis Brown**.

- ✍ **A minimum of 20 complimentary tickets** may be requested by Artist, unless stipulated otherwise by the terms of the Contract. These tickets or guest list spots are generally for street teamers, as well as friends, and we ask that you honor this that we may best promote our date with you. Management also reserves the right to request 5 additional complimentary tickets for Media or VIP guests.
- ✍ **Tour Manager shall have reasonable access** to the box office or ticketing area and shall be provided with verifiable ticket sales or attendance counts upon request.
- ✍ **Artist laminates** will also be honored by venues. Laminates are used to identify crew members, photographers and members of the artist's team, and are NOT distributed to fans and friends.
- ✍ **Merchandise-** Artist will be provided a lighted space and a table to display and sell merchandise. Unless stipulated otherwise in the Contract, Artist will sell all merchandise and retain all proceeds.
- ✍ **Parking-** Well-lit, FREE parking for one (1) vehicle-- a maxi-van-- **must** be provided in close proximity to venue and must be available for the duration of the evening from load-in to load-out.
- ✍ **Insurance-** Buyer or Venue must carry public liability and property damage insurance with sufficiently high limits to adequately insure against bodily injury, death, or loss of or damage to property in connection with a part of the performance. Buyer and/or Venue shall also indemnify Artist against any and all loss, damage and/or destruction occurring to Artist, their employees, contractors and agents, and equipment at the venue, including but not limited to damage or destruction due to acts of God.

Hospitality:

- ✍ **Meals-** Unless stipulated otherwise in the Contract, Buyer will provide a hot, well-balanced meal (with beverage) for five, to be scheduled in advance with the Artist's tour manager. A meal buyout of \$15.00 per person (\$75 USD) is acceptable. Meal buy-out must be presented to Artist tour manager at load-in.
- ✍ **Dressing Room-** A well-lighted, private, lockable dressing room and bathroom (with shower if available) must be provided for the duration of the evening.
- ✍ Artist and/or tour manager **MUST** have free access to a phone and an internet connection if so requested.
- ✍ The following (prioritized) items should be placed in dressing room prior to sound check:
 - (6) towels (to be returned after the show)
 - (2) cases of beer (import or micro-brew ONLY) or 48 drink tickets
 - (1) case of cold SPRING WATER (no Dasani, Aquafina etc.)
 - (12) assorted, chilled Glaceau Vitamin Waters
 - (12) Red Bull Energy Drinks
 - (1) bottle of Maker's Mark whiskey
 - hot coffee (with cream, sugar) to be refilled as requested
 - bucket of rocks ice for drinks (not for chilling beverages)
 - (1) large veggie and fruit platter, consisting of FRESH (and if available, organic) local produce
 - 1 bowl of fresh fruit, including a couple of ripe bananas
 - plates, utensils, cups, napkins and ice as is appropriate
- ✍ **Lodging-** Unless stipulated otherwise in the Contract, Buyer will provide two (2) double occupancy non-smoking room at a nearby established hotel chain, i.e. Comfort Inn, Motel 6, Holiday Inn, etc. for the evening of performance, and will provide Artist with a confirmation number when show is advanced.
Be sure to guarantee the rooms for late arrival and late check-out!

Tech / Production (INPUT LIST & STAGE PLOT attached as separate document):

* **With regards to equipment sharing,** Artist will not share any equipment with other acts on the bill, unless arrangements are made in advance with Tour Manager. If Artist is headlining, Artist WILL NOT strike any gear from the stage, and WILL NOT move instruments and equipment if they deem it to be burdensome, problematic or unnecessary.

The following is true and necessary, unless stipulated on the face of the contract or agreed by Tour Manager to in an advance email:

- ✍ Artist requires no back-line equipment and WILL NOT use back-line if they choose not to.
- ✍ Buyer must provide PA, monitors and all mics, stands, clips and cables.
- ✍ Buyer must provide an engineer to set-up, check and mix front-of-house and monitor sound.
- ✍ Engineer should be available from load-in to load-out.
- ✍ Artist requires a full sound check of at least 40 minutes.

Hollis Brown Stage Plot & Input List

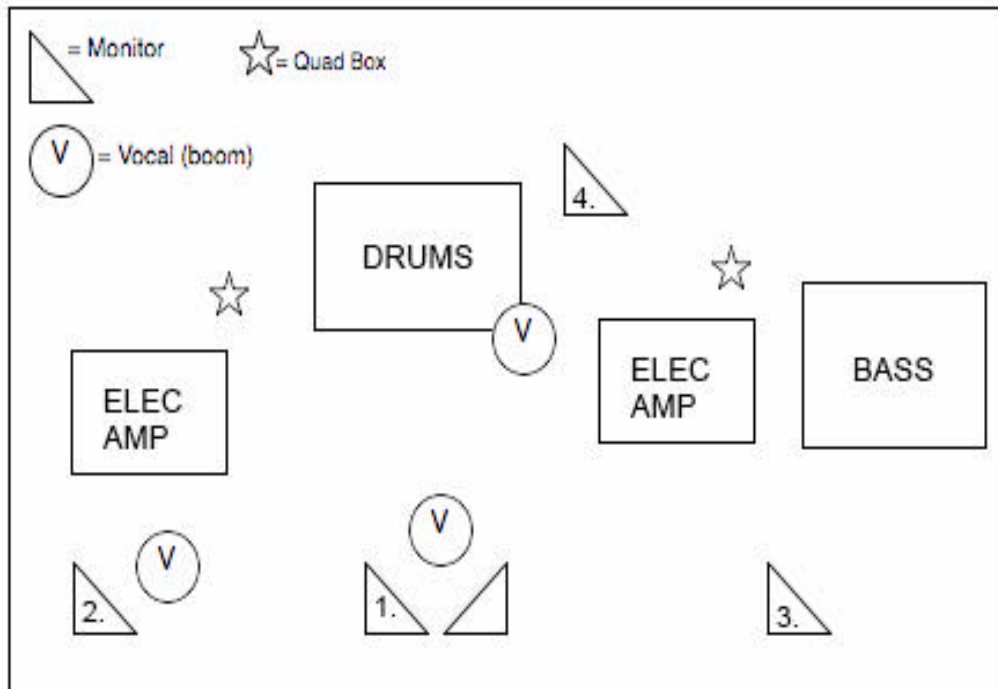

CH	Name	Device	Stand
1	Kick	Beta 52	Short
2	Snare	SM 57	Short Boom
3	Fl. Tom	e604 or Beta 98	Clip
4	Rack Tom	e604 or Beta 98	Clip
5	Hat	sm 81	Short Boom
6	OH L	sm 81	Tall Boom
7	OH R	sm 81	Tall Boom
8	Bass DI	countryman	n/a
9	Bass mic	senn 421	short
10	Guitar 1	sm 57	Short
11	Guitar 2	sm 57	Short
12	Lead Vocal	sm 58	Tall Boom
13	BG Voc 1	sm 58	Tall Boom
14	BG Voc 2	sm 58	Tall Boom
Monitors			
Aux 1	Lead Vox/Guit (Montali)	2 x wedge	
Aux 2	Guitar/BGV (Bonilla)	1 x wedge	

